



QUICK START MANUAL

Applicable For **RM-CEM** Actuators
With Stand-alone Controller

(Please read this MANUAL before use.)

More Technical Support

- MODBUS Communication Parameters
- CANOPEN Communication Parameters
- Secondary Development SDK and Interface Parameters

Please Visit the Website: <https://doc.rmaxis.com>

Customer Service / After Sales Hotline: +86 0757 2220 5682
Website (Product Information Download): www.rmaxis.com
Foshan Augmented Intelligence Technology Co.,Ltd

A. Preparation

1. Are the Products Complete?

Please check whether the model and quantity of the product received inside the package corresponds to the "Sales Delivery Sheet".

Sales Delivery Sheet				
Client Name: xxx Co.Ltd Contact Person: Zhang Xiaoming Contact Num: xxx xxxx xxxx Address: xxx xxx xxxx, China			Delivery Date: 2022-08-08 Serial Num: xxxx xxxxx Remark: xxx	
No.	Item	Unit	Quantity	Remark
1	RM-GB-11-20-2 Gripper	pcs	78	
2	RM-CEM Controller	pcs	78	
3	CB-RM-CEP-ME Cable	pcs	78	
4	USB-485 module	pcs	5	

2. Matching



The model number of the controller should match exactly with the Actuator.



Model Label on the RM-CEM Controller

Match



Model Label on the RM Actuator

3. Extra Items Prepared by User

- 1) Output power supply: DC24V±10%; please refer to the controller label for rated current.
- 2) A PC.

Minimum System Requirements of the PC	
Processor	Intel® or AMD processor with 64-bit support
Operating system	Windows 10 (64-bit) version or above
RAM	2GB

4. Controlling Software Platform

Please contact our after-sales engineer for the software installation zip package.

5. Parameters & Description of the Controller

Parameters of RM-CEP Controller	
Model	RM-CEM
Number of control axes	Single Axis
Voltage power	DC24V±10%
Rated current	2~5.5A
Control method	CC-Link、ModbusRTU
LED display	Red, yellow and green status lights
Cable length	≤ 10m, standard 3/5/10m
Usage environment	<ul style="list-style-type: none">• Ambient temperature for use: 0-40°C• Environmental humidity for use: 85% RH or less (non-condensing state)• Environment for use: avoid using in strong light source, strong ultraviolet ray, corrosive gas environment• Environment temperature for preservation: -10°C -65°C• Environmental humidity for preservation: 90% RH or less (not in condensation state)
Size	116mm×99mm×33mm
Weight	180g
Protection level	IP20
Cooling	Natural convection cooling



Hot plugging is prohibited.

The power supply and cable of the actuator cannot be hot plugging while it's working, which will cause damage to both the actuator and controller.

B. Wiring of Actuators

Depending on the product design of different product models, or different optional cable connectors selected by user, you may receive the following types of and cable. Please follow the corresponding guidelines for wiring of actuators.

1. Actuator with Extended Cable

① Standard

The cable is protected by plastic injection.

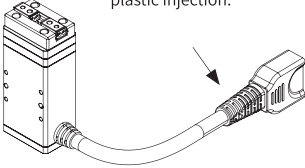

② Optional

The cable is not protected by plastic injection.

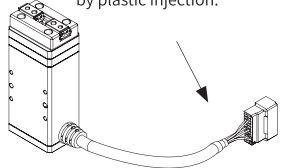

Cables for Connection

Both two types of cables support the above-mentioned actuator with fixed connector.

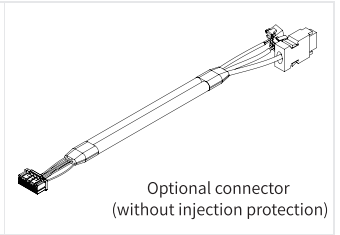
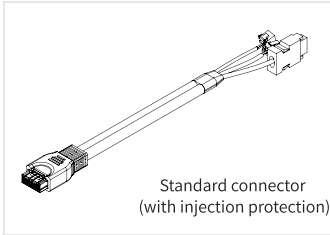

Correctly Tie the Cables

① Cable fixing for standard connector (Injection moulded Connector)

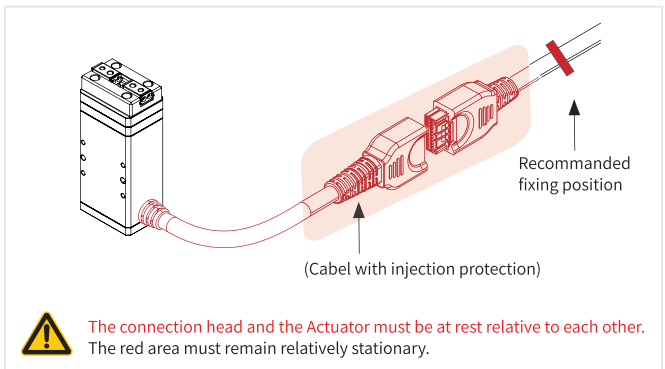

② Cable fixing for optional connector (No injection Connector)

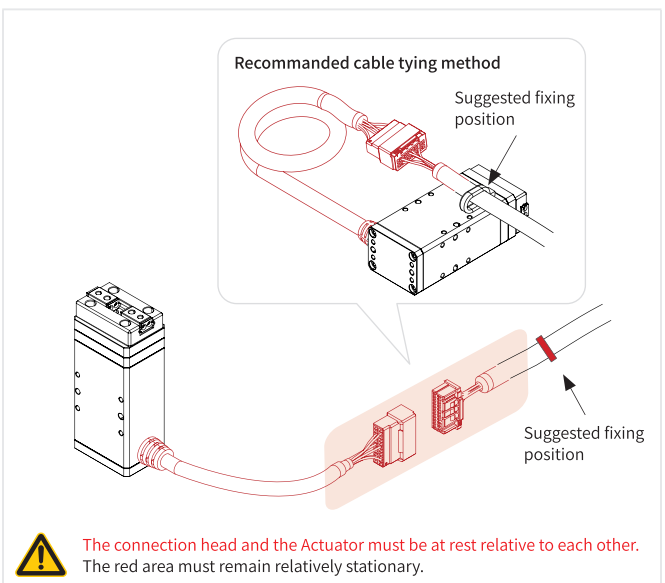

2. Actuators with Fixed Connector

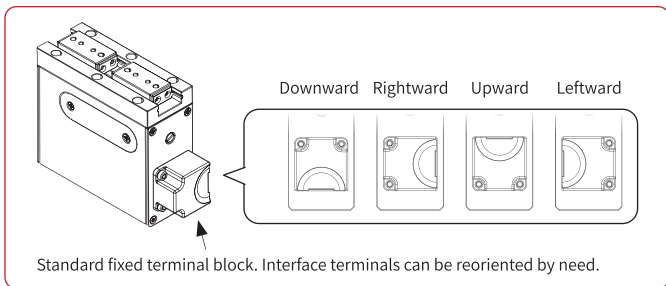

Cables for Connection

Both two types of cables support the above-mentioned actuator with fixed connector.

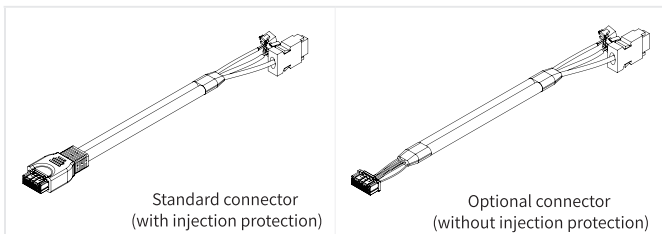

Correctly Tie the Cables

① Cable fixing for standard connector (Injection moulded Connector)

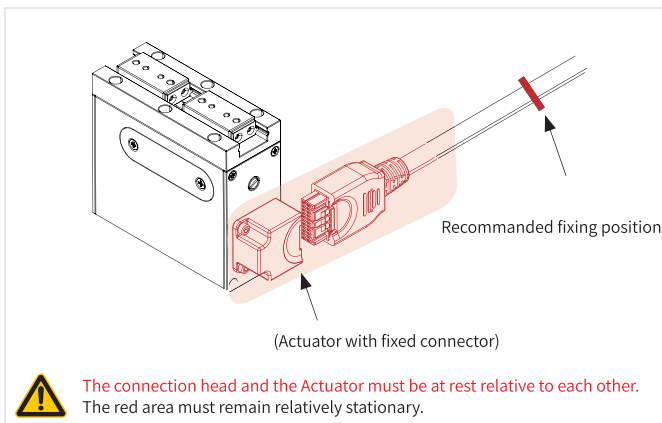

② Cable fixing for optional connector (No injection Connector)

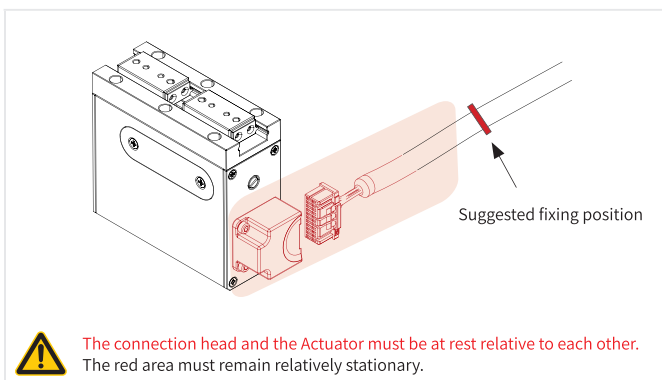

Lower cable method

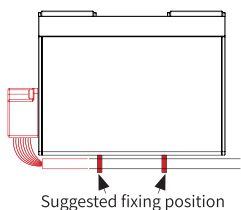

Middle cable fixing method

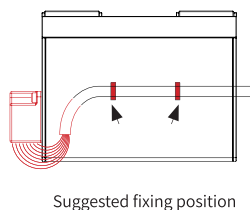

C. Connection of the RM Actuator to the Controller

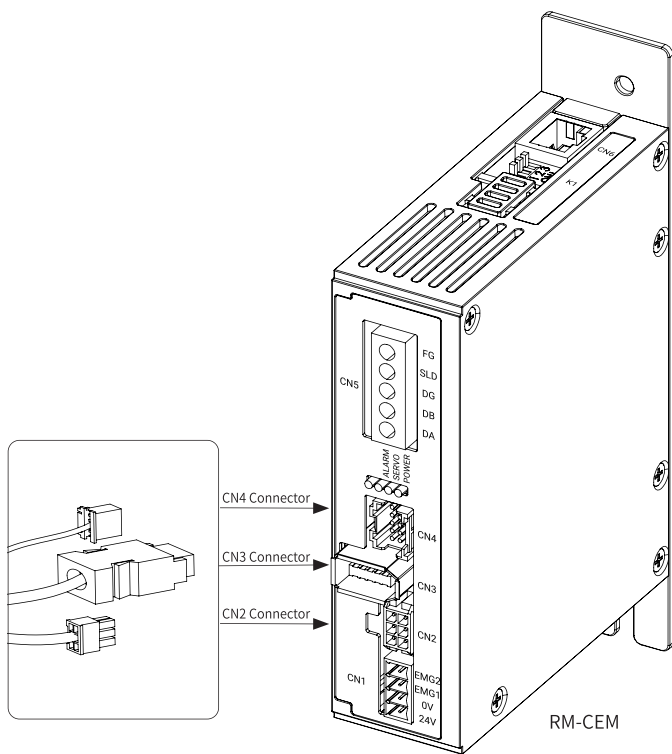

D. Description of the Controller Bus Connection



RJ45 Plug Function Identification		
RJ45	Function	RJ45 - Connector
RJ45-1	485-SGA	
RJ45-2	485-SGB	
RJ45-3	N/A	
RJ45-4	485-VCC-5V*	
RJ45-5	N/A	
RJ45-6	N/A	
RJ45-7	485GND	
RJ45-8	N/A	

CC-Link Communication Interface	
No.	Label
1	FG
2	SLD
3	DG
4	DB
5	DA

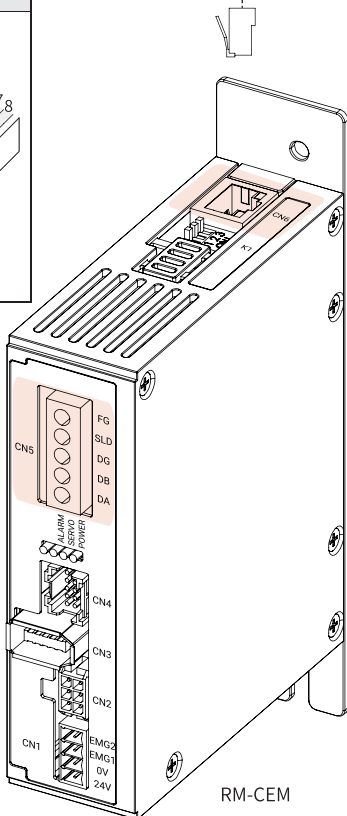

The controller interface needs to be connected to PC with USB-485 module, please do not connect the controller directly to the computer network port/router to avoid damaging the device.

E. Wiring Instructions for Power Supply and Emergency Stop Switch

1. Power Supply Wiring Method

Please keep EMG-KM1 and EMG-KM2 shorted.

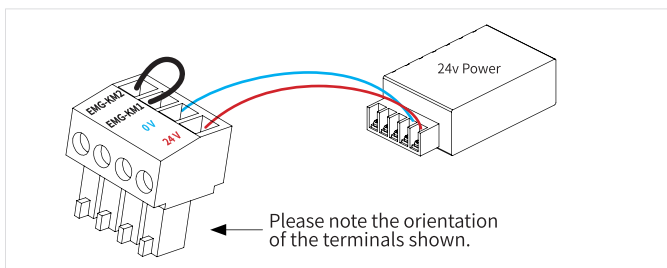

2. Motor Emergency Stop Switch Wiring Method

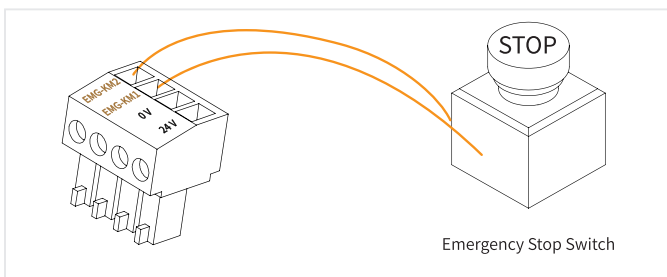

3. Controller Indicator Description

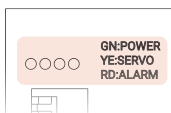

	<input type="radio"/> <input type="radio"/> <input type="radio"/> <input checked="" type="radio"/>	<input type="radio"/> <input checked="" type="radio"/> <input type="radio"/> <input type="radio"/>	<input type="radio"/> <input checked="" type="radio"/> <input type="radio"/> <input type="radio"/>
Status	Green light on	Yellow light on	Red light on
Description	Normal power on	Servo on	Run alarm



Please use a power supply with sufficient power for the power supply. Insufficient power will cause abnormal movement of the Actuator and can lead to damage in severe cases.

F. RMS Control Software Platform

1. Software Installation

- 1) Extract software compressed file.
- 2) Double-click the "RMS software" to run it.
- 3) Please click the "Connect Device" object to start connecting the actuator.

2. Device Connection

1) Modbus RTU

1. [Connection Type], Select "Modbus RTU".
2. [Connection Config], choose the baudrate "115200" (factory default); station ID select "1" (factory default).
3. Click [Connect].

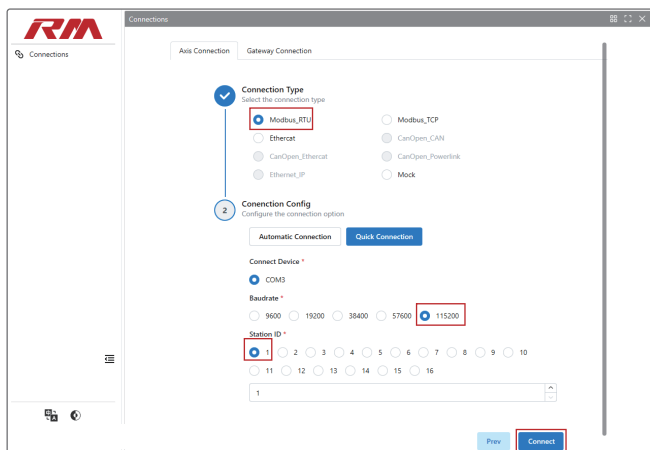

2) Modbus TCP

1. [Connection Type], Select "Modbus TCP".
2. [Connection Config], IP address: 192.168.0.233 (factory default); port: 502 (factory default); station ID: 1 (factory default).
3. Click [Next].

3) EtherCAT

1. [Connection Type], Select "EtherCAT".
2. [Connection Configuration] Please refer to the actual displayed network card device, which can be checked through the computer's control panel under "Network Connections"; Station Number: 0 (default at factory).
3. Click [Connect].

3. Quick Introduction to the Operation Interface

The presence of the navigation bar on the left side of the interface, as depicted in the figure below, signifies that the software has established a successful connection with the controller. Upon each connection, the software automatically retrieves the current parameters from the controller.

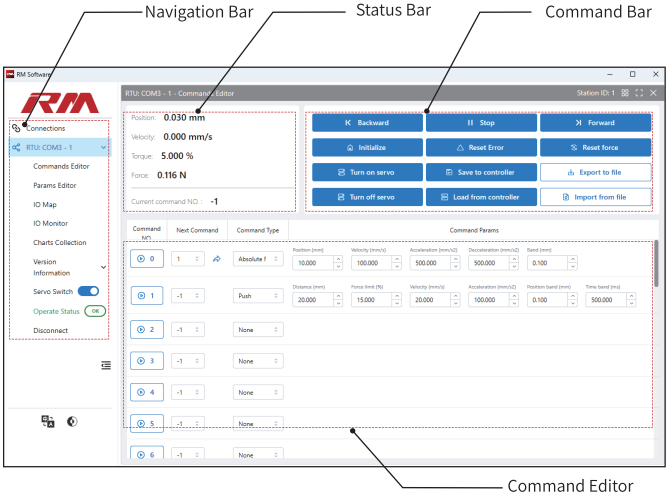

4. Detailed Explanation of Command Types

1) [Absolute Move] Command

The Absolute Move Command is a motion command for the actuator to move to a set position using the origin as a reference point.

Command No.	Next Command	Command Type	Command Params				
0	1	Absolute	Position (mm): 30.000	Velocity (mm/s): 20.000	Acceleration (mm/s ²): 100.000	Deceleration (mm/s ²): 100.000	Band (mm): 0.100
1	-1	Absolute	Position (mm): 0.000	Velocity (mm/s): 20.000	Acceleration (mm/s ²): 100.000	Deceleration (mm/s ²): 100.000	Band (mm): 0.500

Command Parameters	Parameter Description
Position (mm)	The target position for "Absolute Move", set the value to be less than the "Maximum Stroke Value" of the corresponding product model parameter.
Velocity (mm/s)	The velocity at which to move to the target position. Set the effective value band to be less than the "Maximum Velocity Value" of the corresponding product model parameter.
Acceleration (mm/s ²)	The acceleration required to move to the target position. The default setting value is 500 mm/s ² .
Deceleration (mm/s ²)	The deceleration required to move to the target position. The default setting value is 500 mm/s ² .
Positioning Band (mm)	Used to set the band for the positioning signal. The default value is 0.1 mm. If the positioning band is set to ± 0.1 mm, when the actuator reaches the target position and the actual position is within ± 0.1 mm of the target position, the controller will generate a positioning completion signal for the current Command. For example, in "Command 0" on the diagram, the "Positioning Band" is set to 0.1mm, and the "Position" is set to 30mm. When the actuator moves within the absolute position band of 29.9-30.1mm, the controller will output the completion signal for "Command 0." Note: The "Positioning Band" is only used to set the band for issuing the positioning signal and does not affect the final set position that the actuator moves to.

2) [Pushing] Command

The Pushing Command refers to starting from the current position, setting a movement at a rated output (current percentage) for a certain distance until the force reaches the set value and then maintaining it.

- For electric grippers, this is an important Command to achieve adaptive gripping. By setting the Absolute Move + Pushing Commands, the "quick approach and flexible gripping" action can be realized.
- For electric linear actuator, this is an important command to achieve adaptive pressing / holding pressure. By setting the "Absolute Move" + "Pushing" command, the action of "rapid approach with flexible pressing" can be realized.

Command No.	Next Command	Command Type	Command Params					
0	1	Absolute	Position (mm): 10.000	Velocity (mm/s): 20.000	Acceleration (mm/s ²): 100.000	Deceleration (mm/s ²): 100.000	Band (mm): 0.100	
1	-1	Push	Distance (mm): 5.000	Force limit (%): 50.000	Velocity (mm/s): 20.000	Acceleration (mm/s ²): 100.000	Position band (mm): 0.100	Time band (ms): 500.000

Command Parameters	Parameter Description
Distance (mm)	The distance that needs to be moved relative to the current position. The set value should be greater than the actual distance from the target position to the current position. When the set value is greater than the maximum stroke value of the corresponding actuator model, the actuator can achieve full-stroke "Pushing".
Force limit (%)	The "Pushing" at the set output percentage (current percentage).
Velocity (mm/s)	The velocity at which to move to the target distance. The set value band is less than the "Maximum Speed Value" of the corresponding product model parameter. The recommended value is 20 mm/s.
Acceleration (mm/s ²)	The acceleration required to move to the target distance, with the default setting value being 100 mm/s ² .
Position Band (mm)	Used to set the band for the positioning signal, with the default value being 0.1 mm. If the positioning band is set to ± 0.1 mm, when the actuator reaches the target position and the actual position is within ± 0.1 mm of the target position, the controller will generate a positioning completion signal for the current instruction. For example, in "Command 1" on the diagram, the "Position Band" is set to "0.1mm", and the "Distance" is set to "10mm". Therefore, when the actuator moves to 9.9mm, it outputs the "Command 1" arrival signal. Note: The positioning band is solely used to define the scope for issuing the arrival signal and does not affect the final set destination of the actuator's movement.
Time Band (ms)	It determines the time band value for the force to be stably in place. In the diagram for command 1, the time band is set to 500ms with an output force of 50%. Once the actuator's output force reaches 50% and is maintained for 500ms, it is judged to be properly positioned in terms of force, and the arrival signal for command 1 is output simultaneously.

3) [Relative Move] Command

The Relative Move Command is a motion command for the actuator to move to a set position using the current position as a reference point.

Command Parameters	Parameter Description
Distance (mm)	The distance that needs to be moved relative to the current position.
Velocity (mm/s)	The velocity at which to move to the target distance, with the set value band being less than the "Maximum Velocity Value" of the corresponding product model parameter.
Acceleration (mm/s ²)	The acceleration required to move to the target distance, with the default setting value being 500 mm/s ² .
Deceleration (mm/s ²)	The deceleration required to move to the target distance, with the default setting value being 500 mm/s ² .
Positioning Band (mm)	Used to set the band for the positioning signal, with the default value being 0.1 mm. If the positioning band is set to ± 0.1 mm, when the actuator reaches the target position and the actual position is within ± 0.1 mm of the target position, the controller will generate a positioning completion signal for the current Command. For example, in "Command 1" on the diagram, the actuator's current position is "2mm", the "Positioning Band" is set to 0.1mm, and the "Distance" is set to 5mm. Therefore, when the actuator moves to the actual position within the band of 6.9-7.1mm, the controller will output the completion signal for "Command 1". Note: The positioning band is only used to set the band for issuing the positioning signal and does not affect the final set position that the actuator moves to.

5. Position Motion Mode Description



Absolute motion should not be used solely for gripping / pressing, as it will cause the actuator to trigger an alarm.

The force for pressing motion is recommended to be set within the range of 30-100%.

For example, when using the RM-GB-11-20-2 gripper to pick up a workpiece approximately 8mm in size, a program for "rapid approach with flexible pressing" can be set up to enhance the equipment's work efficiency. The procedure is as follows: First, the gripper uses the "Absolute Move" command to quickly approach the object, and then switches to the next command "Pressing Move" when the fingers are about 2mm away from the workpiece. The specific operation is as follows:

- 1) Click on the [Command Editing] ;
- 2) Create two points in the interface, and in sequence, select [Absolute Motion] and [Pressing Motion] in the [Command Type], and modify the corresponding parameters.
- 3) Set the [Next Step] in sequence to "1" and "-1". (If multiple commands need to be executed, you can edit the [Next Step] to set the number of the next command to jump to after the current point is completed, set "-1" for no jump.)
- 4) If the command is set, please click [Save Command to Controller].
- 5) Please click [] at [Point 0] in the command editing interface to run the program.
- 6) The actuator runs according to the set program, please pay close attention to its motion status.

6. Power-Up Home Position Setting



After the actuator performs the "Pushing", do not use the "Initialize" command to open it. Instead, set an "Absolute Move" to "0mm" to achieve "returning to the origin" or move to the desired position.

The actuator is set to automatically return to the home position by default before leaving the factory, and manual operation is generally not required.

If the electric actuator needs to "enable" or "cancel" the automatic return to the home position upon power-up, first connect the software using Modbus RTU or other methods. In [Parameter Editor], search for "auto" and find [cmd_manager.auto_start_command_index]. When the parameter [cmd_manager.auto_start_command_index] is set to "34," the actuator enables the automatic execution of the home position action upon power-up; when this parameter is set to "-1," the actuator cancels the automatic execution of the home position action upon power-up. After completing the change, click [Save Params To Controller]. The actuator/controller will take effect after being powered on again.

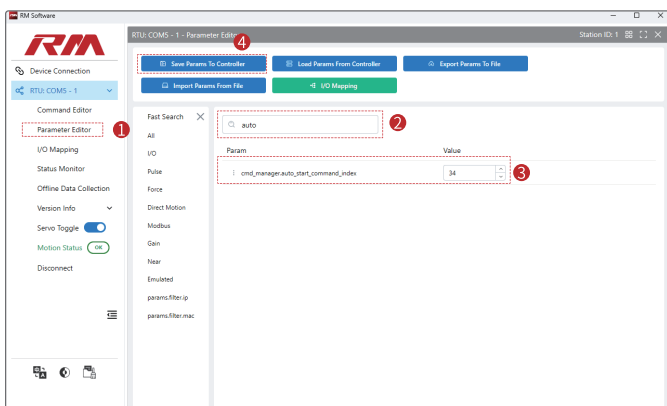

7. Controller Location Assignment

Input Variables	Enter Signal Address	Output Variable	Output Variable Address	Type of Data
IO control enable	0	in_position in place signal	0	Bit
Reset error	1	Alarm	1	Bit
Servo switch	2	Servo feedback signal	2	Bit
Return to origin	3	Reserve	3	Bit
Reserve	4	Location out of tolerance	4	Bit
Reserve	5	Speed is too bad	5	Bit
Reserve	6	Motor stalled	6	Bit
Reserve	7	Reserve	7	Bit
Trigger point 0	8	Point 0 in place signal	8	Bit
Trigger point 1	9	Point 1 in place signal	9	Bit
Trigger point 2	10	Point 2 in place signal	10	Bit
.....
Trigger point 31	23	Point 31 in place signal	23	Bit

Note:

- RX F ~ RX 0 correspond to input signal addresses: 15 ~0;
- RX 1F ~ RX 10 correspond to input signal addresses: 31~16;
- RY F ~ RY 0 corresponds to the output signal address: 15 ~0;
- RY 1F ~ RY 10 correspond to output signal addresses: 31~16.

Variable	Address	Number of registers	Type of data
Target location	0	2	Float
Target speed	2	2	Float

Note: RWw0 ~ RWw1: target position; RWw2 ~ RWw3: target speed.

Variable	Address	Number of registers	Type of data
Current location	0	2	Float
Current speed	2	2	Float

Note: RWr0 ~ RWr1: current position; RWr2 ~ RWr3: current speed.

G.Quick Guide to Maintenance

1. Overviews

1) Use for the First Time

Before the initial use, please confirm whether the interval from the date of receipt to the first use exceeds half a month (reduce appropriately in winter). If it does, it is recommended to apply a small amount of WD-40 rust-preventing lubricant to the actuator's screw rod, guide rail, and other transmission components before use, and move back and forth 3-5 times to allow the lubricant to fully contact the transmission components, ensuring the actuator is in optimal condition.

2) Unused for A Long Time

It is necessary to first apply a small amount of WD-40 rust-preventing lubricant before use, especially when accessing travel ranges that have not been utilized for a long time.



- WD-40 rust-preventing lubricant should only be used in the aforementioned situations.
- For regular daily maintenance, please use NSL grease.
- Please use lubricants that are compatible with the specified grease to avoid abnormal chemical reactions that could cause mechanical damage.

2. Frequency of Maintenance

	Regular check of transmission parts	Regularly check the tightness of the connecting screws	Regular grease replenishment
First time of use	○		
After one month of operation	○	○	
After six months of operation	○	○	○
After one year of operation	○	○	○
Every six months thereafter	○	○	○

The above suggestion period is based on regular operation of 5 working days a week (8 hours/day).

If the Actuator is to be operated around the clock or used at high frequency and/or in a relatively harsh environment (e.g. dusty, high temperature, etc.), the maintenance frequency should be shortened relatively.

3. Key Maintenance Parts of Different Product Models

	Frequency of grease refilling	Area of grease refilling
RM-GB Series	Opening and closing for 100W times or half year	Guide rails and filaments
RM-MGBD Series	Opening and closing for 100W times or half year	Guide rails
RM-PLA/RPLA/WPLA Series	Every 100KM or half year of operation	Guide rails
RM-SLD/RSLD Series	Every 100KM or half year of operation	Guide rails and filaments
RM-RT Series	Every 200W runs or six months	Gears

4. Replacement of Dustproof Sheets

- If the dustproof sheet is bent, chipped, broken and in other abnormal situation, it needs to be replaced in time, otherwise the service life of the RM Actuator will be affected.
- If you need to replace the dustproof sheet, please contact our after-sales engineers.

5. Surface Cleaning

- The exposed transmission part of the Actuators and its surroundings should be kept clean, and be cleared and lubricated regularly, including the slide rails of the grippers, slide rails and telescopic rod of the sliders, etc.
- When there is heavy stains on the Actuators, please use a soft cloth with a little neutral detergent or alcohol and gently wipe it off.
- It is recommended to clean the Actuators thoroughly in a regular basis. Or you can determine a suitable frequency of cleaning to the Actuators depending on its working environment.
- For grippers, it is recommended to manually open and close the jaws for 3-5 times each time before it's power-on and/or it change its stroke, in order to keep the grippers in the best condition. It will also help to prevent accruing abnormal power-up movement or error code 6 caused by large resistance introduced by the slider.

The above section is for quick instructions only.

For more information, please refer to **RM Actuator Maintenance Guide**.