

单位: mm

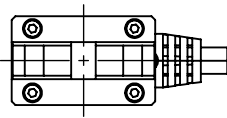
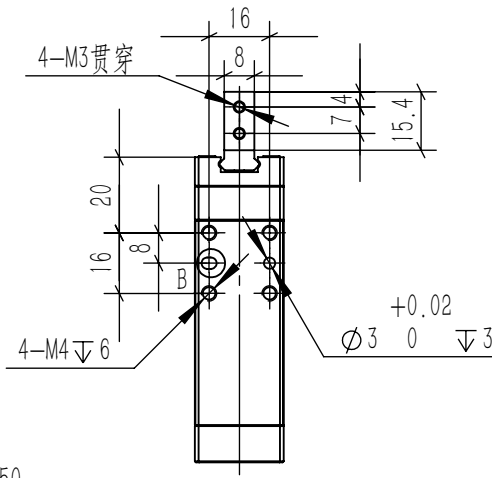
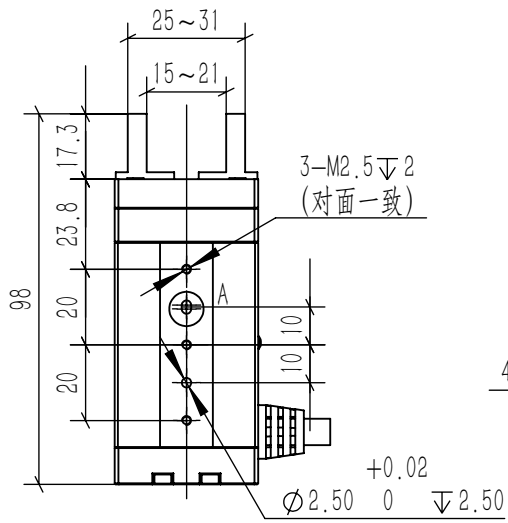
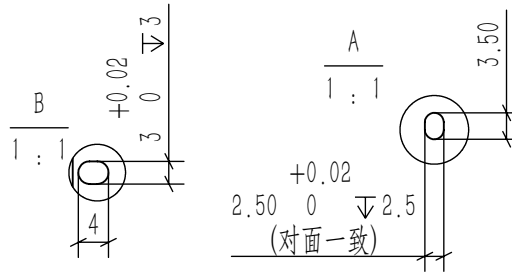
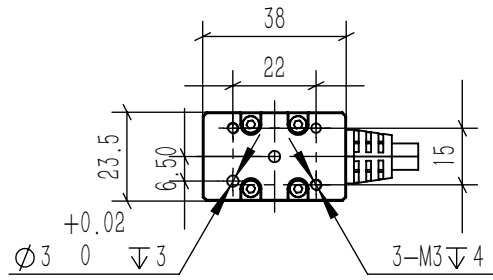

安装说明:

1. 主体固定时, 请使用同一安装面上的所有螺纹孔固定;
2. 拧紧螺栓时, 不得超过螺纹孔深度;